



# Quality Definition for Bronze Worm Gears

---

## CONTENTS:

1 Objective and area of application	P.2
2 Samples	P.2
2.1 Quantity	P.2
2.2 Microsection	P.3
2.2.1 Shape and location	P.3
2.2.2 Preparation	P.5
2.3 Tensile specimen	P.6
2.3.1 Shape and location	P.6
3 Determining the quality criteria	P.6
3.1 Crystalline structure	P.6
3.1.1 Grain size	P.6
3.1.2 Proportion of $\delta$ phases and volume deficit as a percentage	P.7
3.2 Mechanical properties	P.8
3.2.1 Hardness (Brinell)	P.8
3.2.2 Mechanical strength properties based on tensile testing	P.8
3.3 Chemical composition	P.8
4 Limit values for the quality criteria	P.9
5 Documentation	P.9
6 References	P.9
Appendix A: Examples of documentation	P.10

- 
- Produced by the working group "Bronze worm gears" and released by the technical committee "Copper casting".
  - The content of this reference Sheet is identical to reference Sheet "771" of the German Research Association Drive Technology e.V. (FVA).

Only applies to English translation: The English translation is believed to be accurate. In case of discrepancies, the German version is alone authoritative.

**Published by: BDG**, Hansaallee 203, 40549 Düsseldorf, Germany  
Available from: [www.bdguss.de](http://www.bdguss.de)



## 1 Objective and area of application

This directive forms the basis of the technical delivery conditions for the delivery of casting parts made from CuSn12Ni2-C (CC484K) in accordance with the EN 1982 [1] standard or any modifications to these conditions agreed between the manufacturer and the customer. If the casting parts are used as a worm gear in helical-worm gear units, application-specific criteria for the crystalline structure, for the mechanical properties, and for the chemical composition. The directive provides practical specifications for the shape and location of the samples required, the sample preparation, the inspection and test procedures, and the documentation of test results. These specifications then form the basis of the application-specific criteria.

## 2 Samples

The samples described in this chapter can be used by the manufacturer or by the customer to test the quality criteria. If the test is carried out by the manufacturer, samples must be taken from suitable sections of the cast. The customer defines the manufacturing conditions and the siting conditions for these cast sections in the order information, see EN 1982. For worm gears, specific casting parts are now prefabricated to include an allowance for the width of the worm gear before they are delivered to the customer. An axial tensile sample (see chapter 2.3.1) cannot usually be taken from this type of prefabricated casting part. In this case, a specific casting part must be ordered so the customer can carry out their test. However, the microsection can be extracted from a complete worm gear and therefore from all prefabricated parts.

### 2.1 Quantity

Experience has shown that the quality criteria for centrifugally cast or continuously cast casting parts are distributed in a fairly rotationally symmetrical pattern. To justify the inspection effort, one microsection and one tensile sample should be extracted from the centrifugally cast or continuously cast casting part to measure the quality criteria. Both samples can be taken from any location around the perimeter of the casting part. If a quality criterion is not met, proof tests should be carried out in accordance with EN 1982 or an agreement should be reached between the manufacturer and the customer. If a different casting process was used to produce the casting parts, the manufacturer and the customer must agree during the order process on the number of microsections to be extracted around the perimeter of the casting part to establish a representative sample of the quality criteria.

### 2.2 Microsection

The microsection is used to determine the grain size and the proportion of  $\delta$  phase and volume deficit as a percentage.

#### 2.2.1 Shape and location

The microsection can be located in either the transverse plane or the radial plane, as shown in Figure 2.1. For continuously cast casting parts, the location must be agreed between the manufacturer and the customer where required. The microsection should be as square as possible and should have an edge length of approximately 20 mm. If the casting part is too small to extract this edge length, the largest edge length possible should be selected.

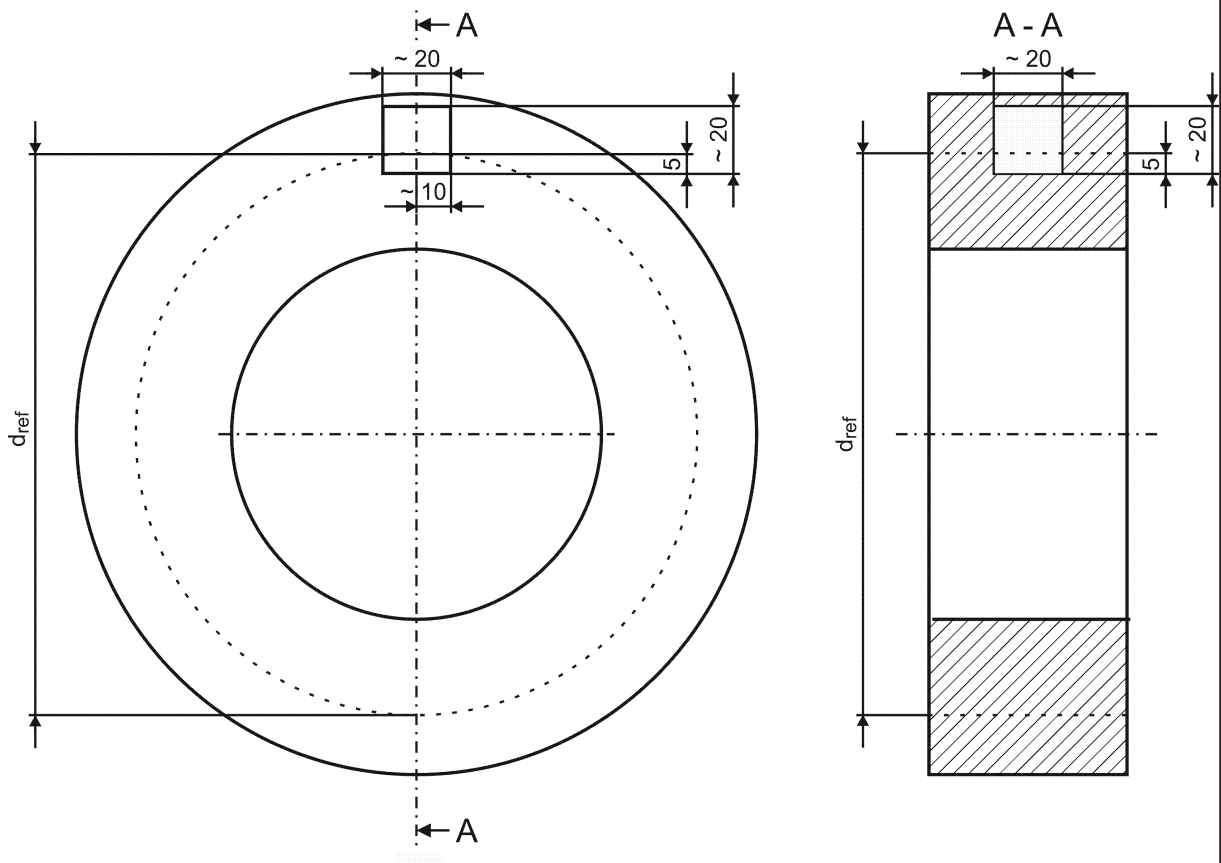

Fig. 2.1: Microsection in the transverse plane (left) and in the radial plane (right)

The radial position of the microsection must also be clearly defined since the quality criteria can vary across the diameter of the casting part. To avoid the complex task of defining the radial position for each specific component as far as possible, the reference diameter  $d_{ref}$  was introduced.



Assuming that the outer diameter of a worm gear  $d_{e2}^1$  is produced by trimming a standard cutting allowance of approximately 2 mm from the rough-turned casting part, the reference diameter can be calculated based on the outer diameter of the rough-turned casting part  $d_v$  using equation 2.2. The diameters  $d_v$ ,  $d_{e2}$ , and  $d_i$  used in equations 2.1, 2.2, and 2.3 must be inserted in mm.

$$d_{ref} = 0.91 \cdot d_v - 13 \text{ mm, assuming that: } d_v = d_{e2} + 2 \text{ mm} \quad (\text{equation 2.1})$$

If, contrary to current industrial applications, the casting part is not ordered from the manufacturer in this rough-turned state, the outer diameter  $d_{e2}$  of the worm gear must be known in order to calculate the reference diameter (see equation 2.2).

$$d_{ref} = 0.91 \cdot d_{e2} - 11 \text{ mm} \quad (\text{equation 2.2})$$

Equations 2.1 and 2.2 are structured in such a way that the calculated reference diameter is less than or the same as the tooth root diameter  $d_{f2}$  of standard worm gears. More accurate positioning based solely on the outer diameter is not possible because worm gears with different tooth heights  $h_2$  can be produced from the same casting part geometry. If the calculated reference diameter is less than the inner diameter of the casting part  $d_i$  available to the inspector which may be the case if the walls are very thin, equation 2.3 must be used to calculate the reference diameter.

$$d_{ref} = d_i + 5 \text{ mm} \quad (\text{equation 2.3})$$

When choosing the position of the microsection in relation to the reference diameter, the lower edge of the microsection must lie 5 mm below the reference diameter. The subsequent tothing area or primary functional area of the casting part is then used as an approximate basis for measuring the quality criteria. If the customer specifies other areas of the casting part as functional areas, separate agreements must be concluded with the manufacturer.

---

<sup>1</sup> Terms from DIN 3975-1 [2] are used to describe the worm gear geometry. The following terms are used: Outer diameter of the worm wheel  $d_{e2}$ , tooth root diameter of the worm wheel  $d_{f2}$ , and tooth height of the worm wheel  $h_2$ .

### 2.2.2 Preparation

This directive does not prescribe a binding procedure for preparing the microsection. The following are simply recommendations for grinding, polishing, and etching. Grinding and polishing are used to produce a flat surface that is free from scratches. When measuring the quality criteria, a grain size of at least 1  $\mu\text{m}$  to polish the surface is recommended. Figure 2.2 below shows a comparison of a well polished microsection (left) and some examples of defective sample preparation (right). Position 1 shows scratches (tracks from previous machining, dirty polishing disk) and position 2 shows striations left by a worn polishing disk. Beside the correct mechanical processing, the cleanliness of the microsection during the photo documentation has to be ensured. To illustrate an unclean microsection, a dust particle can be seen in position 3.

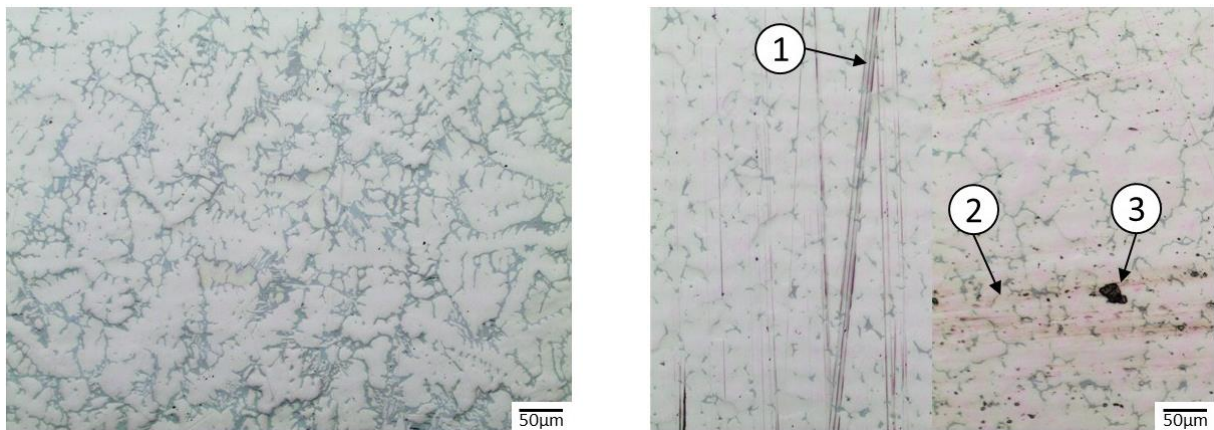

Fig. 2.2: A well prepared microsection (left) and examples of preparation errors (right)

To determine the grain size, the polished microsection is treated with a suitable etching solution. The Adler [3] etching solution has proven successful in industry. Whether a high-contrast grain boundary etching can be achieved is essentially down to the judgment of the metallographer. As a guideline, etching should only take several seconds using freshly prepared solution. Figure 2.3 below shows a well etched microsection (left) and two examples of unsuccessful etching (right). In example 1, the grain boundaries are no longer visible due to over-etching. In example 2, the grain boundaries are not visible in parts due to insufficient etching.



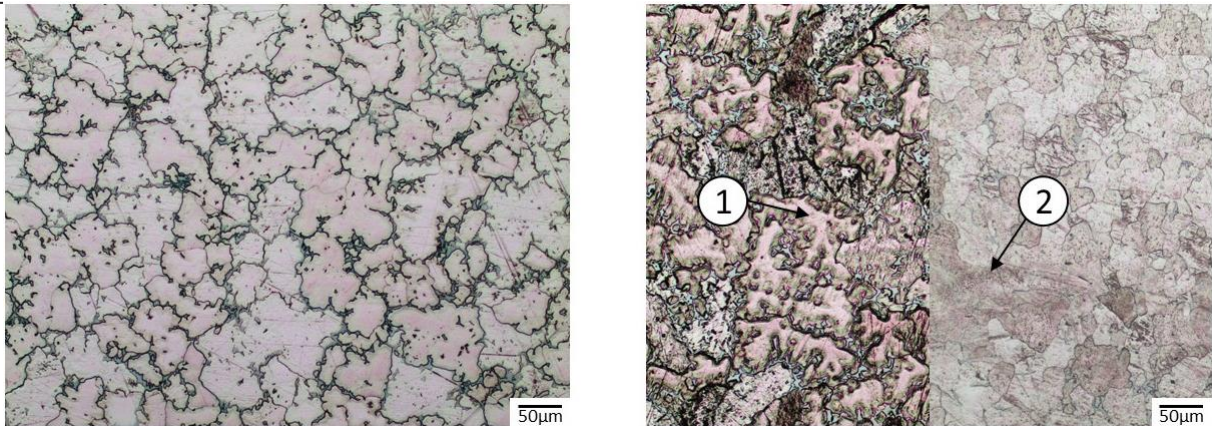

Fig. 2.3: A well etched microsection (left) and examples of unsuccessful etching (right)

### 2.3 Tensile specimen

The tensile specimen is used to determine the relevant mechanical strength properties.

#### 2.3.1 Shape and location

The tensile specimen must be in accordance with DIN 50125 [4]. Based on practical experience, a nominal diameter  $d_0 = 10$  mm is recommended. Tests involving samples with smaller nominal diameters result in greater variations due to the inhomogeneous crystalline structure. EN 1982 specifies the sampling location depending on the casting process and the dimensions of the casting part. Practical studies have shown that the results of the tensile test vary depending on whether the sampling direction is axial or tangential. When comparing test results, the sampling direction must be taken into account. As well as observing the specifications in EN 1982, the tensile specimen should be taken as close to the outer edge as possible depending on the rough turning dimension.

## 3 Determining the quality criteria

### 3.1 Crystalline structure

#### 3.1.1 Grain size

The grain size of the etched microsection can either be measured according to the ASTM E-112-13 [5] procedure or according to DIN EN ISO 2624 [6]. The nominal grain size is a mean value calculated from three individual measurements. The individual measurements correspond to the reference diameter  $d_{ref}$  and are evenly distributed across the width of the microsection.

### 3.1.2 Proportion of $\delta$ phase and volume deficit as a percentage

The proportional coverage of areas for the  $\delta$  phase and for the volume deficits<sup>2</sup> are determined using quantitative image analysis of the non-etched microsection in accordance with the procedure described in BDG directive P211 [7]. Figure 3.1 (left) shows three different colored areas: The light basic matrix (1), the darker  $\delta$  phase (2), and the volume deficits that appear almost black in color (3).

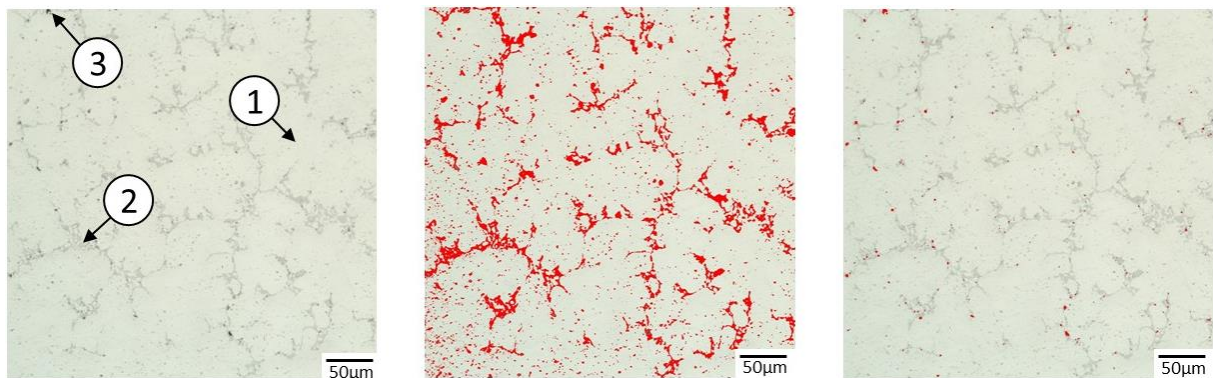

Fig. 3.1: Non-etched microsection (left) with colored areas identified by color thresholds:  
 $\delta$  phase (center) and volume deficits (right)

By counting the colored areas identified by color thresholds, computer programs carry out visual image analysis to determine the proportional coverage of each colored area. Figure 3.1 shows the colored areas used to determine the proportion of the area covered by the  $\delta$  phase (center) and by the volume deficits (right). The proportions of the area are considered quality criteria for bronze worm gears. It is important to note that other elements, for example nonmetallic inclusions, defects, or preparation errors, may appear in the microsection. Due to their color, it may not be possible to distinguish these elements from the proportion of the  $\delta$  phase or the volume deficits using this procedure.

The proportion of the area is a mean value calculated from at least three individual measurements.

<sup>2</sup> The term volume deficits includes hot cracks, shrinkage porosities, and gas porosities, see BDG directive P211 [7].



The procedure for determining the size of the area to be evaluated for an individual measurement should generally be identical to the procedure for determining the grain size in accordance with ASTM E-112-13 or DIN EN ISO 2624. A different procedure can be agreed between the manufacturer and the customer depending on the crystalline structure. The individual measurements should be evenly spaced at the elevation of the microsection. If the crystalline structure is highly inhomogeneous, additional individual measurements may be required to obtain a representative mean value for the proportion of  $\delta$  phase. If in doubt, the number of individual measurements must be agreed between the manufacturer and the customer. As well as the differences in material properties, measuring methods, and analysis methods, the influence of the operator can lead to inaccuracies when measuring the proportions of the areas during quantitative image analysis. These inaccuracies must be taken into account when evaluating the proportions of the areas.

### 3.2 Mechanical properties

#### 3.2.1 Hardness (Brinell)

The hardness measurement can be taken from the casting part in accordance with EN 1982, from the microsection, or from the tensile specimen in accordance with EN ISO 6506-1 [8]. Contrary to the ball diameters mentioned in EN 1982, the test with a ball diameter of 5 mm and a test force of 2452.5 N or the test with a ball diameter of 10 mm and a test force of 9807 N have proven successful in industry. According to EN ISO 6506-1, this procedure corresponds to a degree of loading of  $0.102 F/D^2 = 10$ . The hardness is calculated from three individual measurements. These measurements must be taken from the reference diameter in accordance with the specifications of EN ISO 6506-1.

#### 3.2.2 Mechanical strength properties based on tensile testing

The tensile test should be carried out according to DIN EN ISO 6892-1 [9]. The values for tensile strength  $R_m$ , 0.2% yield strength  $R_{p0.2}$ , and the elongation at break  $A$  must be determined as quality criteria.

### 3.3 Chemical composition

The analysis should be carried out according to EN 1982.





## 4 Limit values for the quality criteria

The specifications of EN 1982 serve as the basis for evaluating the mechanical properties and the chemical composition of the material CuSn12Ni2-C (CC484K). There are currently no standardized limit values to determine the crystalline structure. If required, limit values can be modified or introduced subject to an agreement between the manufacturer and the customer.

## 5 Documentation

Appendix A shows an example of the documentation of test results for the quality criteria described in this directive. The content of this documentation can be used as a template for the technical section of an inspection certificate according to DIN EN 10204 [10]. The scope and level of detail of an inspection certificate must be agreed between the manufacturer and the customer.

## 6 References

- [1] EN 1982 – Copper and copper alloys, Beuth Verlag, 2008
- [2] DIN 3975-1 – Definitions and parameters on cylindrical worm gear pairs with rectangular crossing shafts – Part 1: Worm and worm wheel, Beuth Verlag, 2012
- [3] Hasse, S., Foundry Lexikon, P.88, Fachverlag Schiele & Schoen, 2007
- [4] DIN 50125 – Testing of metallic materials – Tensile test pieces, Beuth Verlag, 2009
- [5] ASTM E-112-13 – Standard Test Methods for Determining Average Grain Size, 2013
- [6] DIN EN ISO 2624 – Copper and copper alloys – Estimation of average grain size, Beuth Verlag, 1995
- [7] BDG directive P211 – Volume deficits of castings made from copper and copper alloys, BDG Foundry Information Center, 2010
- [8] EN ISO 6506-1 – Brinell hardness test, Beuth Verlag, 1999
- [9] DIN EN ISO 6892-1 – Tensile testing – Part 1: Method of test at room temperature, Beuth Verlag, 2009
- [10] DIN EN 10204 – Metallic products – Types of inspection documents; German version EN 10204:2004, Beuth Verlag, 2005



## Appendix A: Examples of documentation

The following tables show documentation of test results for the quality criteria described in this technical specification. The table fields completed in grey in the examples must be filled in by the inspector.

**Table A.1: Chemical composition**

Chemical composition according to EN 1982						Material		CuSn12Ni2-C-GZ				
Element	Cu	Sn	Ni	P	Zn*	Pb	Fe*	Sb	Mn	S	Al	Si
	[%]	[%]	[%]	[%]	[%]	[%]	[%]	[%]	[%]	[%]	[%]	[%]
Min	84.5	11.0	1.5	0.05	–	–	–	–	–	–	–	–
Max	87.5	13.0	2.5	0.4	0.4	0.3	0.2	0.1	0.2	0.05	0.01	0.01
Actual	85.0	12.0	2.0	0.15	0.1	0.05	0.1	0.04	0.1	0.01	–	–

**Table A.2: Hardness**

Hardness (Brinell) according to EN ISO 6506-1, EN 1982		Ball diameter:	
		5 mm	<input checked="" type="checkbox"/>
Reference diameter $d_{ref}$ :	160 mm	10 mm	<input type="checkbox"/>
Measurement		Hardness [HB]	
1		100	
2		110	
3		105	
Arithmetic mean value		105	
Setpoint		min. 95	

Only applies to English translation: The English translation is believed to be accurate. In case of discrepancies, the German version is alone authoritative.

Published by: **BDG**, Hansaallee 203, 40549 Düsseldorf, Germany  
Available from: [www.bdguss.de](http://www.bdguss.de)



**Table A.3: Mechanical strength properties**



<b>Mechanical strength properties</b> according to DIN EN ISO 6892-1 and EN 1982		Sampling direction:	
Sampling location:	External	Tangential	<input checked="" type="checkbox"/>
Nominal diameter:	10 mm	Axial	<input type="checkbox"/>
Value	Rm	Rp 0.2	A
	[N/mm <sup>2</sup> ]	[N/mm <sup>2</sup> ]	[%]
<b>Actual</b>	<b>325</b>	<b>200</b>	<b>10</b>
Min	300	180	8.0

Only applies to English translation: The English translation is believed to be accurate. In case of discrepancies, the German version is alone authoritative.

**Published by: BDG**, Hansaallee 203, 40549 Düsseldorf, Germany  
Available from: [www.bdguss.de](http://www.bdguss.de)



Table A.4: Grain size

<b>Grain size</b>		<b>Process:</b>	
		ASTM E-112-13	<input checked="" type="checkbox"/>
Reference diameter $d_{ref}$ :	160 mm	DIN EN ISO 2624	<input type="checkbox"/>
<b>Measurement</b>	<b>Evaluated granular area</b>	<b>Measured value [<math>\mu\text{m}</math>]</b>	
1		105	
2		86	
3		82	
<b>Nominal grain size (arithmetic mean value)</b>		<b>91</b>	
<b>Setpoint</b>		-	

Only applies to English translation: The English translation is believed to be accurate. In case of discrepancies, the German version is alone authoritative.

Published by: BDG, Hansaallee 203, 40549 Düsseldorf, Germany  
Available from: www.bdguss.de



**Table A.5: Proportion of the  $\delta$  phase**

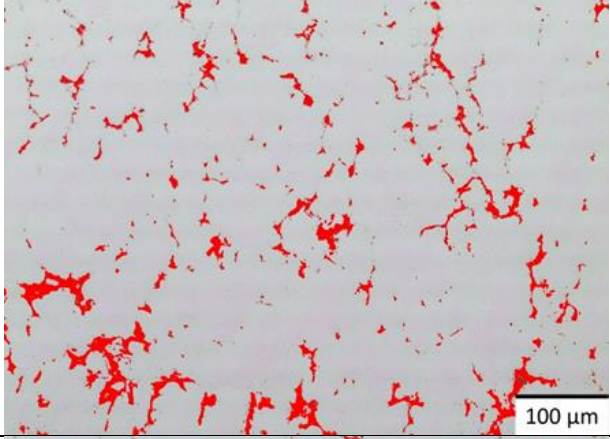
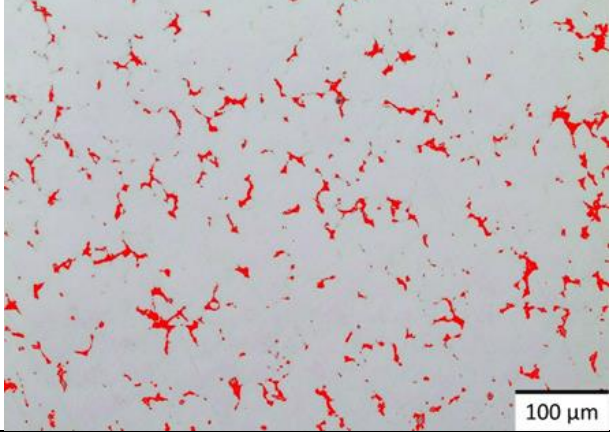

Proportion of the $\delta$ phase			
Reference diameter $d_{ref}$ :	160 mm	Investigator:	001
Measurement	Evaluated granular area	Proportion of the $\delta$ phase as a percentage [%]	
1		5.6	
2		5.2	
3		4.8	
<b>Arithmetic mean value</b>		5.2	
Setpoint		–	

Only applies to English translation: The English translation is believed to be accurate. In case of discrepancies, the German version is alone authoritative.



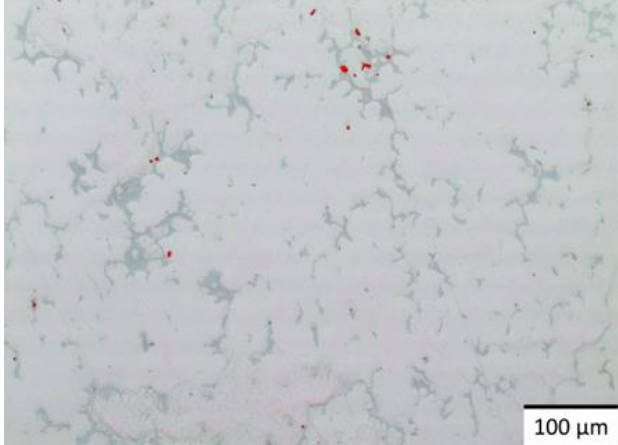
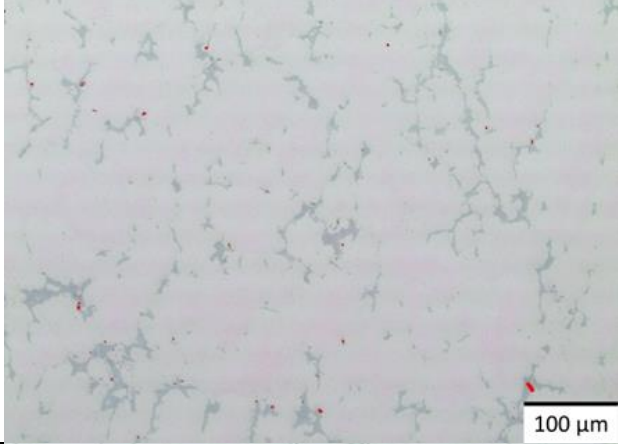

**Table A.6: Proportion of the volume deficit**

Proportion of the volume deficit			
Reference diameter $d_{ref}$ :	160 mm	Investigator:	001
Measurement	Evaluated granular area	Proportion of the volume deficit as a [%]	
1		0.06	
2		0.04	
3		0.03	
<b>Arithmetic mean value</b>			<b>0.04</b>
Setpoint			–

Only applies to English translation: The English translation is believed to be accurate. In case of discrepancies, the German version is alone authoritative.

**Published by: BDG**, Hansaallee 203, 40549 Düsseldorf, Germany  
Available from: [www.bdguss.de](http://www.bdguss.de)